

(19)



Europäisches Patentamt

European Patent Office

Office européen des brevets



(11)

EP 0 774 237 B1

(12)

EUROPEAN PATENT SPECIFICATION

(45) Date of publication and mention
of the grant of the patent:
02.04.2003 Bulletin 2003/14

(51) Int Cl.⁷: **A61B 17/00**, A61B 17/128,
A61B 17/122

(21) Application number: **961 16909.1**

(22) Date of filing: **21.10.1996**

(54) **Apparatus for vascular hole closure**

Vorrichtung zur Gefässwundverschliessung

Dispositif de fermeture d'une plaie vasculaire

(84) Designated Contracting States:
DE ES FR GB IT

(30) Priority: **20.10.1995 US 545974**

(43) Date of publication of application:
21.05.1997 Bulletin 1997/21

(73) Proprietor: **United States Surgical Corporation**
Norwalk, Connecticut 06856 (US)

(72) Inventors:
• **Green, David T.**
Westport, CT 06880 (US)

• **Manzo, Scott E.**
Shelton, CT 06484 (US)
• **Hinchliffe, Peter W.J.**
New Haven, CT 06515 (US)

(74) Representative: **Marsh, Roy David et al**
Hoffmann Eitle,
Patent- und Rechtsanwälte,
Arabellastrasse 4
81925 München (DE)

(56) References cited:
WO-A-92/22252 **US-A- 4 929 240**
US-A- 5 242 456 **US-A- 5 304 184**
US-A- 5 342 393

EP 0 774 237 B1

Note: Within nine months from the publication of the mention of the grant of the European patent, any person may give notice to the European Patent Office of opposition to the European patent granted. Notice of opposition shall be filed in a written reasoned statement. It shall not be deemed to have been filed until the opposition fee has been paid. (Art. 99(1) European Patent Convention).

Description**BACKGROUND****1. Technical Field**

[0001] The present disclosure relates to an apparatus for closing a hole or puncture in a blood vessel, and more particularly, to an apparatus for applying a surgical clip to a blood vessel to close a hole formed therein during an intravascular catheterization procedure. Apparatus to deploy a surgical closure to close a hole in a blood vessel wall, in accordance with the pre-characterising part of claim 1 below, is disclosed in US-A-5-342 393.

2. Background of Related Art

[0002] When performing a catheterization procedure such as, for example, an angiography or angioplasty, a sharpened hollow needle is first percutaneously introduced into the vascular system. A guide wire is then inserted through the hollow needle and into the lumen of a selected blood vessel. Subsequently, the needle is removed and a dilator and/or introducer is fed into the vessel along the guide wire. The guide wire is then removed and a suitable catheter is fed through the lumen of the introducer and advanced through the vascular system until the working end thereof is positioned at the operating site. At the conclusion of the catheterization procedure, the catheter is withdrawn, and subsequently, the dilator and/or introducer is also removed from the wound.

[0003] At this point in the procedure, the vessel puncture must be sealed in order to stem the flow of blood therethrough. Because it is often common practice to administer a blood thinning agent to the patient prior to the catheterization procedures, stemming the blood flow can be troublesome. A common method of healing the wound is to maintain external pressure over the vessel until the puncture naturally seals. This method of puncture closure typically takes about thirty minutes, with the length of time usually being greater if the patient is hypertensive or anti-coagulated. When hand pressure is utilized, it can be uncomfortable for the patient and can use costly professional time on the part of the hospital staff. Other pressure application techniques, such as pressure bandages, sandbags or clamps, have been employed, but these devices also require the patient to remain motionless for an extended period of time and the patient must be closely monitored to ensure their effectiveness.

[0004] Other devices have been disclosed which plug or otherwise provide an obstruction in the area of the puncture. See, for example, U.S. Patent Nos. 4,852,568 and 4,890,612, wherein a collagen plug is disposed in the blood vessel opening. When the plug is exposed to body fluids, it swells to create a block for the wound in the vessel wall. A potential problem of plugs introduced

into the vessel is that particles may break off and float downstream to the point where they may lodge in a smaller vessel, causing an infarct to occur. Collagen material also acts as a nidus for platelet aggregation and, therefore, can cause intraluminal deposition of hemostatic agent, thereby creating the possibility of a thrombosis at the puncture sight. Other plug-like devices are disclosed, for example, in U.S. Patent Nos. 5,342,393 (already mentioned above); 5,370,660; and 5,411,520.

[0005] Surgical clips and clip applicators are known and have been used in vascular surgery, particularly to join severed vessels. See, for example, U.S. Patent No. 4,929,240 (Kirsch, et al.). The clips disclosed in the '240 Patent provide an advantage over suturing by decreasing the likelihood of clotting and vascular damage, particularly in micro-vascular repair procedures. While vascular clips have been successfully used in surgery, the surgical procedures in which the clips are used typically allow the surgeon to view the area to be clipped. In catheter puncture repair procedures, however, the wound is generally not visible, making proper clip application, if attempted, difficult.

[0006] Therefore, there is a need for surgical techniques and apparatus suitable for closing punctures in blood vessels, particularly those created during catheterization procedures. This need requires a reliable hemostasis of the puncture in a quick and efficient manner. It would also be advantageous to close the puncture without disposing any foreign substances within the vessel, thereby preventing the likelihood of introducing foreign matter into the circulatory system. The technique also needs to be performed without directly viewing the punctured vessel.

SUMMARY

[0007] The present invention is defined in claim 1 below. Dependent claims are directed to optional or preferred features.

The subject application describes apparatus and method for applying a surgical clip to an exterior wall of a blood vessel to at least partially close a hole formed therein during a catheterization procedure. The apparatus includes a handle portion, an elongate body extending distally from the handle portion and dimensioned to extend through a hole in the wall of a blood vessel, and a collapsible locator operatively associated with the elongate body and mounted for movement between a collapsed retracted position disposed within a distal end portion of the elongate body and an expanded deployed position extending from the distal end portion of the elongate body. The locator forms, in its deployed position, a locator loop and is adapted and configured to expand within an interior lumen of the blood vessel in the deployed position to maintain the distal end portion of the elongated body in a desired location with respect to the hole in blood vessel wall. A surgical clip is releasably supported adjacent the distal end portion of the elongate

body which is configured for application to the exterior wall of the blood vessel to at least partially close the hole formed therein when the locator is substantially in the deployed position.

[0008] The surgical clip has a pair of opposed clip legs connected by a bail portion, and the bail portion has an aperture provided therein to accommodate movement of the locator from the deployed position to the retracted position upon application of the clip to the exterior wall of the blood vessel. A control rod may extend from the handle portion through the elongate body and may be mounted for movement between a proximal position and a distal position to effectuate the movement of the collapsible locator between the retracted position and the deployed position, and a control knob may be operatively mounted to a proximal end of the control rod to facilitate the longitudinal movement thereof. The control knob preferably includes means for releasably engaging the handle portion when the collapsible locator is disposed in the deployed position.

[0009] In a preferred embodiment of the subject apparatus, the elongate body includes an outer tubular member mounted for axial movement with respect to the handle portion between a proximal position and a distal position, and structure is provided adjacent a distal end of the elongate body for releasably supporting the surgical clip. A pair of diametrically opposed camming ramps are preferably formed adjacent a distal end of the elongate body, distal of the clip support structure, to cause the opposed legs of the surgical clip to move between a closed position and an open position in response to longitudinal movement of the outer tubular member from the distal position toward the proximal position.

[0010] An actuation handle is operatively associated with the handle portion of the surgical apparatus and is mounted for manipulation through an actuating stroke. Preferably, movement of the actuation handle through a first segment of the actuating stroke causes the outer tubular member to move from the proximal position to the distal position, and movement of the actuation handle through a second segment of the actuating stroke causes the actuation rod to move from the distal position to the proximal position. In addition, movement of the actuation handle through the second segment of the actuating stroke releases the control knob from an engaged position.

[0011] In a preferred embodiment of the surgical apparatus disclosed herein, distal and proximal actuating members are supported within the handle portion and are operatively connected to the actuation handle. Preferably, a first control link connects the distal actuating member to the actuation handle and second control link connects the proximal actuating member to the actuation handle. The distal actuating member is also connected to a proximal end of the outer tubular member, and the proximal actuating member is also connected to a release tube which is dimensioned to interact with

the control knob upon movement of the actuation handle through the second segment of the actuating stroke.

[0012] The method disclosed (but not claimed) herein includes the steps of taking an elongate body having a surgical clip supported adjacent a distal end portion thereof, extending the elongate body through the hole in the blood vessel such that at least a distal end portion thereof projects into an interior lumen of the blood vessel, and deploying a locator from the distal end portion of the elongate body into the interior lumen of the blood vessel to maintain the elongate body in a desired position with respect to the hole in the wall of the blood vessel. The method further includes the steps of applying the surgical clip to the exterior wall of the blood vessel to at least partially close the hole therein, and retracting the locator from the interior lumen of the blood vessel.

[0013] The method step of applying the surgical clip can include the step advancing the surgical clip in a distal direction from a proximal support position on the elongate body, and the step of moving the surgical clip between open and closed positions. The step of deploying the locator includes the step of moving the locator from a collapsed position within the distal end position of the elongate body to an expanded position extending from the distal end portion of the body. Preferably, the step of withdrawing the locator is concomitant with the step of applying the surgical clip to the exterior wall of the blood vessel.

[0014] Further features of the surgical apparatus of the subject application will become more readily apparent to those skilled in the art from the following detailed description of the apparatus and method taken in conjunction with the drawings.

BRIEF DESCRIPTION OF THE DRAWINGS

[0015] Various embodiments of the surgical apparatus of the subject application will be described hereinbelow with reference to the drawings wherein:

Fig. 1 is a perspective view of a surgical apparatus constructed in accordance with a preferred embodiment of the subject invention in a pre-operative condition;

Fig. 2 is an enlarged perspective view of the distal end portion of the surgical apparatus of Fig. 1 illustrating the surgical clip releasably supported thereon;

Fig. 3 is an exploded perspective view of the elongate body of the surgical apparatus of Fig. 1 with the components thereof separated for ease of illustration;

Fig. 4 is an enlarged perspective view of the distal end portion of the elongate body of Fig. 3 illustrating the surgical clip and clip support structure associ-

ated therewith;

Fig. 5 is an enlarged perspective view of the distal end portion of the clip advancement tube of the elongate body illustrated in Fig. 3;

Fig. 6 is a perspective view of the handle portion of the surgical apparatus of Fig. 1 with the left housing section removed to illustrate the internal components housed therein;

Fig. 7 is an exploded perspective view of the handle portion shown in Fig. 6 with the components thereof separated for ease of illustration;

Fig. 8 is an exploded perspective view of the locator and the distal end portion of the control rod to which the locator is mounted;

Fig. 9 is an enlarged perspective view of the coupling area of the locator illustrated in Fig. 8;

Fig. 10 is a perspective view of the locator in an expanded condition mounted to the distal end of the control rod;

Fig. 11 is a perspective view of a cannula extending through a hole in the wall of a blood vessel with the elongate body of the surgical apparatus of Fig. 1 extended therethrough;

Fig. 12 is an enlarged perspective view of the locator extended from the distal end portion of the surgical apparatus of Fig. 1 and collapsed within the cannula;

Fig. 13 is a side elevational view in cross-section of the handle portion of the surgical apparatus of Fig. 1 illustrating the relative orientation of the internal components associated therewith in a pre-operative condition;

Fig. 14 is a side-elevational view in cross-section of the handle portion of the surgical apparatus of Fig. 1 illustrating the relative orientation of the internal components associated therewith in a condition corresponding to the locator being disposed in a deployed position;

Fig. 15 is a perspective view of a distal end portion of the elongate body of the surgical apparatus of Fig. 1 illustrating the locator disposed in a deployed position within the interior lumen of a blood vessel;

Fig. 16 is a side elevational view in cross-section of the handle portion of the surgical apparatus of Fig. 1 illustrating the relative orientation of the components associated therewith in positions correspond-

ing to the clip advancement tube being advanced toward a distal position;

Fig. 17 is a perspective view of the distal end portion of the elongate body of the surgical apparatus of Fig. 1 illustrating the clip advancement tube advanced distally to cause the surgical clip to move to an open position;

Fig. 18 is a side-elevational view corresponding to Fig. 17 and illustrating the surgical clip in an open position;

Fig. 19 is a perspective view of the distal end portion of the elongate body of the surgical apparatus of Fig. 1 illustrating the clip advancement tube advanced to a distal-most position to cause the surgical clip to move to a closed position;

Fig. 20 is a side elevational view corresponding to Fig. 19 and illustrating the surgical clip in a closed position;

Fig. 21 is a side elevational view in cross-section of the handle portion of the surgical apparatus of Fig. 1 illustrating the relative orientation of the components associated therewith in positions corresponding to the locator being withdrawn to a retracted position; and

Fig. 22 is a side elevational view of the surgical clip applied to the exterior wall of the blood vessel to close the hole formed therein.

DETAILED DESCRIPTION OF PREFERRED EMBODIMENTS

[0016] In the drawings and in the description which follows, the term "proximal", as is traditional, will refer to the end of the apparatus which is closest to the operator, while the term "distal" will refer to the end of the apparatus which is furthest from the operator.

[0017] Referring now to the drawings wherein like reference numerals identify similar structural elements disclosed herein, there is illustrated in Fig. 1 a surgical apparatus constructed in accordance with a preferred embodiment of the subject application and designated generally by reference numeral 10. Surgical apparatus 10 is adapted and configured to apply a surgical clip to the exterior wall of a blood vessel to at least partially close a hole formed therein during a catheterization procedure, such as, for example, an angioplasty or angiography procedure.

[0018] Referring to Fig. 1, surgical apparatus 10 includes a handle assembly 12 consisting of right and left housing sections 12a and 12b which together define an elongated barrel portion 14, a stationary handle 16 depending from barrel portion 14, and a pivoting actuation

handle or trigger 18 mounted for movement with respect to stationary handle 16. An elongate body 20 extends distally from the barrel portion 14 of handle assembly 12, and a surgical clip 22 is releasably supported on a distal end portion of elongated body 20, as illustrated in Fig. 2. As best seen in Fig. 4, surgical clip 22 includes a pair of opposed clip legs 24a and 24b connected to one another by a bail portion 26. Each clip leg is provided with a pair of tissue engagement projections 25 for securely engaging the exterior wall of the blood vessel to which it is applied (see Fig. 22). Clip legs 24a and 24b are normally biased into a closed position resulting from the overall configuration of surgical clip 22 and the material from which the clip is constructed. The material of construction may be selected from bio-compatible materials, including, for example, stainless steel, titanium, and tantalum. Other materials of construction such as bioabsorbable polymers are also envisioned.

[0019] Referring to Fig. 3, the elongate body 20 of surgical apparatus 10 includes a main support shaft 30 having an elongate bore 30a extending therethrough. Support shaft 30 extends through the barrel portion 14 of handle assembly 10 and is mounted adjacent a proximal end thereof in a conventional manner. A clip support fixture 34 is mounted in axial bore 30a adjacent the distal end of support shaft 30. As best seen in Fig. 4, support fixture 34 is configured to releasably support surgical clip 22 and includes a pair of diametrically opposed rails 36a and 36b dimensioned to interact with a crescent shaped aperture 38 defined in the bail portion 26 of surgical clip 22. Rails 36a and 36b terminate in distally extending camming ramps 40a and 40b, respectively, which effectuate movement of clip legs 24a and 24b between closed and open positions as surgical clip 22 is advanced in a distal direction during a hole closing procedure.

[0020] Advancement of surgical clip 22 in a distal direction relative to camming ramps 40a and 40b is accomplished through the axial translation of an elongate pusher tube 42. Pusher tube 42 is mounted coaxial with support shaft 30 and is configured to translate with respect thereto in response to manipulation of actuation handle 18 to drive surgical clip 22 distally. As best seen in Fig. 5, spaced apart arcuate engagement fingers 44a and 44b project distally from pusher tube 42 to engage the crescent spaced aperture 38 defined in the bail portion 26 of surgical clip 22. Diametrically opposed elongate slots 46a and 46b are formed in the distal portion of pusher tube 42 to accommodate rails 36a and 36b during the distal translation of the pusher tube with respect to support shaft 30.

[0021] Referring now to Figs. 6 and 7, a set pin 45 fixedly connects the proximal end of pusher tube 42 to a distal actuation block 48 which is housed within the barrel portion 14 of handle assembly 12. Actuation block 48 includes opposed lateral guide ribs 50a and 50b which translate within opposed guide slots formed in the interior surfaces of right and left housing sections 12a

and 12b, i.e., guide slot 53. A coupling link 54 connects distal actuation block 48 to actuation handle 18 such that manipulation of actuation handle 18 causes actuation block 48 to translate distally, urging pusher tube 42 in a distal direction. Coupling pins 54a and 54b pivotally connect coupling link 54 to actuation block 48 and actuation handle 18.

[0022] Referring now to Figs. 8-10, surgical apparatus 10 also includes a locator 60 in the form of a collapsible loop adapted and configured to maintain the distal end portion of elongate body 20 in a desired position with respect to the hole in the wall of a blood vessel during a hole closing procedure. Locator 60 includes a pair of locator arms 62 and 64 which are constructed from a resilient material that preferably displays shape memory characteristics, such as, for example, a material or alloy consisting of a composition of nickel and titanium. Locator arms 62 and 64 include elongate proximal extension portions 62a and 64a, respectively, and arcuate expansion portions 62b and 64b, respectively. As best seen in Fig. 9, the terminal end of arcuate expansion portion 62b includes an engagement notch 63 for receiving and retaining a complementary engagement finger 65 formed at the terminal end of arcuate expansion portion 64b. When engaged and situated in a relaxed unstressed condition, resilient expansion portions 62b and 64b form an endless loop-like structure. As best seen in Fig. 8, when assembled, the proximal ends of extension portions 62a and 64a are approximated and secured to a coupling flange 66 which is provided at the distal end of an elongate control rod 68 which facilitates movement of locator 60 with respect to support tube 30 during a hole closing procedure.

[0023] Referring again to Figs. 6 and 7, the elongate control rod 68 extends through the axial bore 30a of support tube 30, into the barrel portion 14 of handle assembly 12, through the axial bores 48a and 70a of distal and proximal actuation blocks 48 and 70, out of the proximal end of barrel portion 14, and into the axial bore 75a of a cylindrical control knob 75 operatively associated with handle assembly 12. The proximal end of control rod 68 is fixedly maintained within axial bore 75a of control knob 75 by a fastener 77 (see Fig. 13). Control knob 75 facilitates the longitudinal translation of control rod 68 between proximal and distal positions, and hence the movement of locator 60 from a collapsed (stressed) position disposed within the axial bore 34a of support fixture 34 to a deployed (unstressed) position extending from the distal end of support fixture 34. Control knob 75 includes a pair of engagement tabs 74a and 74b for releasably engaging a pair of complementary retention notches formed on the exterior of housing sections 12a and 12b, i.e., retention notch 76, when locator 60 is disposed in a deployed position.

[0024] With continuing reference to Figs. 6 and 7, an elongate release tube 78 extends proximally from the proximal actuation block 70 to interact with, and effect the disengagement of, control knob 75 upon manipula-

tion of actuation handle 18. More particularly, proximal actuation block 70, which includes guide ribs 72a and 72b that translate within opposed guide slots formed in housing sections 12a and 12b, i.e., guide slot 73, is connected to actuation handle 18 by a coupling link 82. Coupling pins 82a and 82b pivotably connect coupling link 82 to actuation block 70 and actuation handle 18. Thus, manipulation of actuation handle 18 causes actuation block 70 to translate in a proximal direction, whereupon release tube 78 enters the axial bore 75a of control knob 75 and urges the control knob proximally to disengage tabs 74a and 74b. As discussed in further detail hereinbelow, the distal and proximal actuation blocks 48 and 70 are connected to actuation handle 18 in such a manner so that control knob 75 will not be released until pusher tube 42 has been advanced to its distal-most position.

[0025] Referring now to Fig. 11, in use, the elongate body 20 of surgical apparatus 10 is introduced into the interior lumen 102 of blood vessel 104 through a conventional cannula 100 which had previously been extended through the hole 106 formed in the wall of blood vessel 104 during the catheterization procedure. Thereupon, locator 60 is moved distally through the translation of control knob 75 from its proximal-most position illustrated in Fig. 13 to its distal-most position illustrated in Fig. 14. Moreover, locator 60 is advanced from its proximal-most position disposed within the axial bore 34a of clip support fixture 34 to its distal-most position extending from the distal end of clip support fixture 34. At such a time, the arcuate expansion portions 62b and 64b of locator arms 62 and 64 remain in a collapsed (stressed) condition restrained within the interior lumen of cannula 100, as best seen in Fig. 12. When control knob 75 is in its proximal-most position shown in Fig. 14, engagement tabs 74a and 74b are releasably engaged to the proximal end of barrel portion 14, thereby securing the longitudinal orientation of control rod 68 and locator 60.

[0026] Referring now to Fig. 15, after locator 60 is moved into its distal-most position, cannula 100 is withdrawn in a proximal direction with respect to elongate body 20 to a retracted position. Consequently, the arcuate expansion portions 62b and 64b of locator arms 62 and 64 move into their deployed (unstressed) positions, forming the loop-like structure which maintains the distal end portion of elongate body 20 in a desired position with respect to the hole 106 in the wall of blood vessel 104. In this deployed position, the geometric plane defined by locator 60 is oriented parallel to the elongation of blood vessel 104. Accordingly, the opposed clip legs 24a and 24b of surgical clip 22 extend in a direction which is perpendicular to the elongation of blood vessel 104.

[0027] Once locator 60 is deployed, the clip application portion of the vascular hole closure procedure may commence. To apply surgical clip 22 to the exterior wall of blood vessel 104 to at least partially close the hole 106 formed therein, actuation handle 18 is initially

moved through the first segment of an actuation stroke, with guide pin 90 serving as the pivot point for actuation handle 18. During this time, actuation handle 18 causes the distal actuation block 48 to translate from its proximal-most position illustrated in Fig. 14 to its distal-most position illustrated in Fig. 16 through a distance " x_d " within the barrel portion 14 of handle assembly 12. As a result, pusher tube 42 is driven distally, urging surgical clip 22 in a distal direction.

[0028] Initially, during the distal advancement of surgical clip 22, the opposed clip legs 24a and 24b of surgical clip 22 are moved to an open position as the clip translates with respect to camming ramps 40a and 40b, as illustrated in Figs 17 and 18. Subsequently, as actuation block 48 approaches its distal-most position within barrel portion 14, pusher tube 42 advances surgical clip 22 past camming ramps 40a and 40b so that clip legs 24a and 24b return to a closed position, as illustrated in Figs. 19 and 20. More specifically, when camming ramps 40a and 40b meet the crescent shaped aperture 38 in the bail portion 26 of surgical 22, clip legs 24a and 24b return to their normally biased closed position.

[0029] Referring back to Fig. 14, prior to the manipulation of actuation handle 18 through the first segment of its actuating stroke, the proximal end of release tube 78 is disposed slightly distal of the axial bore 75a of control knob 75. As shown in Fig. 16, however, during the manipulation of actuation handle 18 through the first segment of its actuating stroke, the proximal actuation block 70 and release tube 78 translate in a proximal direction through a distance " x_p " which is substantially less than the distance " x_d " through which the distal actuation block 48 travels during the same period of time. Consequently, during the first segment of the actuating stroke of actuation handle 18, the proximal end of release tube 78 translates only a short distance within the axial bore 75a of control knob 75, remaining free from contact with the proximal wall of axial bore 75a, and having no effect of the longitudinal position of control knob 75.

[0030] However, as illustrated in Fig. 21, once the distal actuation block 48 reaches its distal-most position, the pivot point of actuation handle 18 transfers from guide pin 90 to coupling pin 54a. As a result, the remaining portion of the actuating stroke of actuation handle 18 is guided by the interaction of guide pin 90 and the arcuate guide slot 92 formed in actuation handle 18. Consequently, further manipulation of actuation handle 18 toward stationary handle 16 urges proximal actuation block 70 in a proximal direction, driving release tube 78 proximally. As a consequence, control knob 75 is urged proximally, causing the release of engagement tabs 74a and 74b from the complementary notches formed at the proximal end of barrel portion 14, and effectuating the proximal withdrawal of control rod 68 relative to support tube 30. Accordingly, the arcuate expansion portions 62b and 64b of locator 60 are withdrawn into the axial bore 34a of support fixture 34, through the crescent

shaped aperture 38 formed in the bail portion 26 of surgical clip 22.

[0031] Following the withdrawal of locator 60 into the axial bore 34a of support fixture 34, the distal end portion of the elongated body 20 of surgical apparatus 10 may be withdrawn from the surgical site. As best seen in Fig. 22, at the conclusion of the procedure, the opposed legs 24a and 24b of surgical clip 22 are securely engaged to the exterior wall of blood vessel 104 such that the hole once formed therein is closed, thereby preventing blood from flowing therethrough.

Claims

1. An apparatus (10) for applying a surgical closure to an exterior wall of a blood vessel which defines an interior lumen of the blood vessel, to at least partially close a hole in the wall of the blood vessel, the apparatus comprising:

a) a handle portion (12) including an actuation handle (18) mounted for movement through an actuating stroke;

b) an elongate body (20) extending distally from the handle portion and dimensioned to extend through the hole in the wall of a blood vessel;

c) a collapsed locator (60) operatively associated with the elongate body and mounted for movement from a collapsed retracted position disposed within a distal end portion of the elongate body to an expanded deployed position extending from the distal end portion of the elongate body, the locator being adapted and configured to expand within the interior lumen of the blood vessel in the deployed position to maintain the distal end portion of the elongate body in a desired location with respect to the hole in the blood vessel wall;

d) the surgical closure;

the apparatus being **characterized in that:**

e) the surgical closure is a surgical clip (22) releasably supported on the distal end portion of the elongate body and configured for application to the exterior wall of the blood vessel to at least partially close the hole formed therein, the surgical clip having a pair of opposed clip legs (24 a, b) biased into a closed position and connected by a bail portion (26), the bail portion having an aperture provided therein to accommodate movement of the locator between the deployed position and the retracted position;

f) an actuation assembly (48, 70) housed within the handle portion and operatively connected to the actuation handle such that movement of the actuation handle through a first segment of the actuating stroke effectuates longitudinal movement of the surgical clip toward the exterior wall of the blood vessel and movement of the actuation handle through a second segment of the actuating stroke effectuates movement of the collapsible locator from the deployed position to the retracted position ; and

g) the locator forms, in its deployed position, a locator loop.

2. An apparatus as recited in claim 1, wherein a control rod (68) extends from the handle portion through the elongate body portion and is mounted for movement between a proximal position and a distal position to effectuate the movement of the collapsed locator loop from the retracted position to the deployed position.

3. An apparatus as recited in claim 2, wherein a control knob (75) is operatively mounted to a proximal end of the control rod to facilitate the longitudinal movement thereof and includes means (74 a, b) for releasably engaging the handle portion when the collapsible locator loop is disposed in the deployed position.

4. An apparatus as recited in claim 3, wherein the elongate body portion includes an outer tubular member (42) mounted for axial movement with respect to the handle portion between a proximal position and a distal position for effectuating said longitudinal movement of the surgical clip.

5. An apparatus as recited in claim 4, wherein a pair of diametrically opposed camming ramps (40 a, b) are formed on a support shaft (30) at a distal end of the elongate body, distal of the clip support position, the camming ramps causing the opposed legs of the surgical clip to move between a closed position and an open position in response to longitudinal movement of the outer tubular member from the distal position toward the proximal position.

6. An apparatus as recited in claim 5, wherein movement of the actuation handle through the first segment of the actuating stroke causes the outer tubular member to move from the proximal position to the distal position, and movement of the actuation handle through the second segment of the actuating stroke causes the control rod to move from the distal position to the proximal position.

7. An apparatus as recited in claim 6, wherein move-

ment of the actuation handle through the second segment of the actuating stroke releases the control knob from its engagement with the handle portion.

8. An apparatus as recited in claim 7, wherein the actuating assembly includes a distal actuating member (48) connected to a proximal end of the outer tubular member and a proximal actuating member (70) connected to a release tube (78) which is dimensioned to interact with the actuator upon movement of the actuation handle through the second segment of the actuating stroke. 5 10
9. An apparatus as recited in any one of the preceding claims, wherein at least a portion of the locator loop is formed from a material having shape memory characteristics. 15
10. An apparatus as claimed in claim 3, wherein the means for releasably engaging the handle portion includes a pair of opposed locking tabs (74 a, b) configured to releasably engage complementary reception structures provided on a proximal end portion of the handle portion when the collapsible locator is disposed in the deployed position. 20 25
11. An apparatus as claimed in any one of the preceding claims, wherein support structure (34) is provided adjacent a distal end of the elongate body for releasably supporting the surgical clip. 30
12. An apparatus as claimed in claim 8, wherein a first control link (54) connects the distal actuating member to the actuation handle and second control link (82) connects the proximal actuating member to the actuation handle. 35

Patentansprüche 40

1. Vorrichtung (10) zum Anbringen eines chirurgischen Verschlusses an eine Außenwand eines Blutgefäßes, die ein inneres Lumen des Blutgefäßes begrenzt, um zumindest teilweise eine Öffnung in der Wand des Blutgefäßes zu schließen, umfassend: 45
- a) einen Griffbereich (12) mit einem Betätigungsgriff (18), der für eine Bewegung mittels eines Betätigungshubs angebracht ist; 50
- b) einen langgestreckten Körper (20), der sich in distaler Richtung vom Griffbereich erstreckt und dimensioniert ist, um sich durch die Öffnung in der Wand eines Blutgefäßes zu erstrecken; 55
- c) einen zusammengeklappten Lokalisierer

(60), der betriebsmäßig dem langgestreckten Körper zugeordnet ist und für eine Bewegung von einer zusammengeklappten, zurückgezogenen Position innerhalb eines distalen Endbereichs des langgestreckten Körpers angeordnet zu einer aufgeweiteten entfalteten Position, die sich von dem distalen Endbereich des langgestreckten Körpers erstreckt, angebracht ist, wobei der Lokalisierer dazu geeignet und gestaltet ist, um sich innerhalb des inneren Lumens des Blutgefäßes in die entfaltete Position aufzuweiten, um den distalen Endbereich des langgestreckten Körpers in einer gewünschten Anordnung in Bezug auf die Wand des Blutgefäßes zu halten;

d) den chirurgischen Verschluss; wobei die Vorrichtung **dadurch gekennzeichnet ist, dass**

e) der chirurgische Verschluss eine chirurgische Klemme (22) ist, die lösbar auf dem distalen Endbereich des langgestreckten Körpers getragen wird und zur Anbringung an die Außenwand des Blutgefäßes gestaltet ist, um zumindest teilweise die darin gebildete Öffnung zu schließen, wobei die chirurgische Klemme ein Paar von gegenüberliegenden Klemmenbeinen (24a, b) besitzt, die in eine geschlossene Position vorgespannt sind und durch einen Bügelbereich (26) verbunden sind, wobei der Bügelbereich eine darin gebildete Öffnung besitzt, um die Bewegung des Lokalisierers zwischen der entfalteten Position und der zurückgezogenen Position aufzunehmen;

f) einen Betätigungsaufbau (48, 70), der innerhalb des Griffbereichs aufgenommen ist und betriebsmäßig mit dem Betätigungsgriff so verbunden ist, dass eine Bewegung eines Betätigungsgriffs durch einen ersten Abschnitt des Betätigungshubs hindurch eine Längsbewegung der chirurgischen Klemme in Richtung auf die Außenwand des Blutgefäßes bewirkt und eine Bewegung des Betätigungsgriffs durch einen zweiten Abschnitt des Betätigungshubs hindurch eine Bewegung des zusammenklappbaren Lokalisierers von der entfalteten Position in die zurückgezogene Position bewirkt; und

g) der Lokalisierer in seiner entfalteten Position, eine Lokalisiererschleife bildet.

2. Vorrichtung gemäß Anspruch 1, wobei eine Regelstange (68) sich vom Griffbereich durch den langgestreckten Körperbereich erstreckt und für eine Bewegung zwischen einer proximalen Position und einer distalen Position angebracht ist, um die Be-

- wegung der zusammenklappbaren Lokalisiererschlaufe von der zurückgezogenen Position in die ausgefahrene Position zu bewirken.
3. Vorrichtung gemäß Anspruch 2, wobei ein Regelknopf (75) betriebsmäßig an einem proximalen Ende der Regelstange angebracht ist, um die Längsbewegung derselben zu erleichtern, und eine Einrichtung (74a, b) aufweist, um lösbar mit dem Griffbereich in Eingriff zu treten, wenn die zusammenklappbare Lokalisiererschlaufe in der entfalteten Position ist. 5 10
 4. Vorrichtung gemäß Anspruch 3, wobei der langgestreckte Körperbereich ein äußeres röhrenförmiges Element (42) aufweist, das für eine axiale Bewegung in Bezug auf den Griffbereich zwischen einer proximalen Position und einer distalen Position angebracht ist, um die Längsbewegung der chirurgischen Klemme zu bewirken. 15 20
 5. Vorrichtung gemäß Anspruch 4, wobei ein Paar von einander diametral entgegengesetzten Verschieberampen (40a, b) auf einer Stützwelle (30) an einem distalen Ende des langgestreckten Körpers distal zur Halteposition der Klemme gebildet sind, wobei die Verschieberampen die gegenüberliegenden Beine der chirurgischen Klemme zwischen einer geschlossenen Position und einer offenen Position in Antwort auf die Längsbewegung des äußeren röhrenförmigen Elements von der distalen Position in Richtung auf die proximale Position bewegen lassen. 25 30
 6. Vorrichtung gemäß Anspruch 5, wobei die Bewegung des Betätigungsgriffs durch den ersten Abschnitt des Betätigungshubs das äußere röhrenförmige Element von der proximalen Position zur distalen Position bewegen lässt und eine Bewegung des Betätigungsgriffs durch den zweiten Abschnitt des Betätigungshubs die Regelstange von der distalen Position in die proximale Position bewegen lässt. 35 40
 7. Vorrichtung gemäß Anspruch 6, wobei die Bewegung des Betätigungsgriffs durch den zweiten Abschnitt des Betätigungshubs den Regelknopf von seinem Eingriff mit dem Griffbereich löst. 45
 8. Vorrichtung gemäß Anspruch 7, wobei der Betätigungsaufbau ein distales Betätigungselement (48) aufweist, das mit einem proximalen Ende des äußeren röhrenförmigen Elements verbunden ist, und ein proximales Betätigungselement (70), das mit einer Löseröhre (78) verbunden ist, die dimensioniert ist, um mit dem Betätiger auf eine Bewegung des Betätigungsgriffs durch den zweiten Abschnitt des Betätigungshubs in Wechselwirkung zu treten. 50 55
 9. Vorrichtung gemäß einem der vorhergehenden Ansprüche, wobei zumindest ein Bereich der Lokalisiererschlaufe aus einem Material mit Formgedächtniseigenschaften gebildet ist.
 10. Vorrichtung gemäß Anspruch 3, wobei die Einrichtung zum lösbaren in Eingriff nehmen des Griffbereichs ein Paar von gegenüberliegenden Verriegelungsansätzen (74a, b) aufweist, die gestaltet sind, um lösbar mit komplementären Aufnahmeaufbauten in Eingriff zu treten, die auf einem proximalen Endbereich des Griffbereichs vorgesehen sind, wenn der zusammenklappbare Lokalisierer in der entfalteten Position ist.
 11. Vorrichtung gemäß einem der vorhergehenden Ansprüche, wobei ein Stützaufbau (34) neben einem distalen Ende des langgestreckten Körpers vorgesehen ist, um lösbar die chirurgische Klemme zu halten.
 12. Vorrichtung gemäß Anspruch 8, wobei eine erste Regelverbindung (54) das distale Betätigungselement mit dem Betätigungsgriff verbindet und eine zweite Regelverbindung (82) das proximale Betätigungselement mit dem Betätigungsgriff verbindet.
- Revendications**
1. Appareil (10) pour appliquer une fermeture chirurgicale à une paroi extérieure d'un vaisseau sanguin qui définit une lumière intérieure du vaisseau sanguin, pour fermer au moins partiellement un trou dans la paroi du vaisseau sanguin, l'appareil comprenant:
 - a) une portion de poignée (12) incluant une poignée d'actionnement (18) installée en vue d'un déplacement par une course d'actionnement;
 - b) un corps oblong (20) s'étendant distalement de la portion de poignée et dimensionné pour s'étendre à travers le trou dans la paroi d'un vaisseau sanguin;
 - c) un localisateur replié (60) fonctionnellement associé au corps oblong et installé en vue d'un déplacement d'une position rétractée repliée disposé dans une portion d'extrémité distale du corps oblong à une position expansée déployée s'étendant de la portion d'extrémité distale du corps oblong, le localisateur étant conçu et configuré pour s'étendre dans la lumière intérieure du vaisseau sanguin dans la position déployée pour maintenir la portion d'extrémité distale du corps oblong à un emplacement sou-

haité par rapport au trou dans la paroi du vaisseau sanguin;

d) la fermeture chirurgicale;

l'appareil étant **caractérisé en ce que**:

e) la fermeture chirurgicale est une pince chirurgicale (22) supportée relâchablement sur la portion d'extrémité distale du corps oblong et configurée pour l'application à la paroi extérieure du vaisseau sanguin pour fermer au moins partiellement le trou formé dans celui-ci, la pince chirurgicale présentant deux branches de pince opposées (24 a, b) sollicitées en une position fermée et reliées par une portion de dos (26), la portion de dos présentant une ouverture dans celle-ci pour recevoir le mouvement du localisateur entre la position déployée et la position rétractée;

f) un ensemble d'actionnement (48, 70) logé dans la portion de poignée et fonctionnellement relié à la poignée d'actionnement de telle sorte que le mouvement de la poignée d'actionnement selon un premier segment de la course d'actionnement produit un mouvement longitudinal de la pince chirurgicale vers la paroi extérieure du vaisseau sanguin, et un mouvement de la poignée d'actionnement selon un second segment de la course d'actionnement produit un mouvement du localisateur repliable de la position déployée à la position rétractée; et

g) le localisateur forme, dans sa position déployée, une boucle de localisateur.

2. Appareil selon la revendication 1, où une tige de commande (68) s'étend depuis la portion de poignée à travers la portion de corps oblong et est installée en vue d'un déplacement entre une position proximale et une position distale pour produire le déplacement de la boucle de localisateur repliée de la position rétractée à la position déployée.
3. Appareil selon la revendication 2, où un bouton de commande (75) est installé fonctionnellement sur une extrémité proximale de la tige de commande pour faciliter le déplacement longitudinal de celle-ci et comporte des moyens (74 a, b) pour venir en prise relâchablement avec la portion de poignée lorsque la boucle de localisateur repliable est disposée dans la position déployée.
4. Appareil selon la revendication 3, où la portion de corps oblong comporte un élément tubulaire extérieur (42) installé en vue d'un déplacement axial par rapport à la portion de poignée entre une position

proximale et une position distale pour effectuer ledit mouvement longitudinal de la pince chirurgicale.

5. Appareil selon la revendication 4, où deux rampes de came diamétralement opposées (40 a, b) sont formées sur un arbre de support (30) à une extrémité distale du corps oblong, distale de la position de support de pince, les rampes de came amenant les branches opposées de la pince chirurgicale à se déplacer entre une position fermée et une position ouverte en réponse à un déplacement longitudinal de l'élément tubulaire externe de la position distale vers la position proximale.
6. Appareil selon la revendication 5, où le déplacement de la poignée d'actionnement sur le premier segment de la course d'actionnement amène l'élément tubulaire externe à se déplacer de la position proximale à la position distale, et un déplacement de la poignée d'actionnement sur le second segment de la course d'actionnement amène la tige de commande à se déplacer de la position distale à la position proximale.
7. Appareil selon la revendication 6, où un déplacement de la poignée d'actionnement sur le second segment de la course d'actionnement sort le bouton de commande de sa prise avec la portion de poignée.
8. Appareil selon la revendication 7, où l'ensemble d'actionnement comporte un élément d'actionnement distal (48) relié à une extrémité proximale de l'élément tubulaire externe et un élément d'actionnement proximal (70) relié à un tube de relâchement (78) qui est dimensionné pour interagir avec l'actionneur lors d'un déplacement de la poignée d'actionnement sur le second segment de la course d'actionnement.
9. Appareil selon l'une des revendications précédentes, où au moins une portion de la boucle de localisateur est réalisée en un matériau ayant des caractéristiques de mémoire de forme.
10. Appareil selon la revendication 3, où les moyens pour venir en prise relâchablement avec la portion de poignée comportent deux pattes de verrouillage opposées (74 a, b) configurées pour venir en prise relâchablement avec des structures de réception complémentaires prévues sur une portion d'extrémité proximale de la portion de poignée lorsque le localisateur repliable est disposé dans la position déployée.
11. Appareil selon l'une des revendications précédentes, où la structure de support (34) est prévue pour être adjacente à une extrémité distale du corps

oblong pour supporter relâchablement la pince chirurgicale.

12. Appareil selon la revendication 8, où une première bielle de commande (54) relie l'élément d'actionnement distal à la poignée d'actionnement et une seconde bielle de commande (82) relie l'élément d'actionnement proximal à la poignée d'actionnement.

10

15

20

25

30

35

40

45

50

55

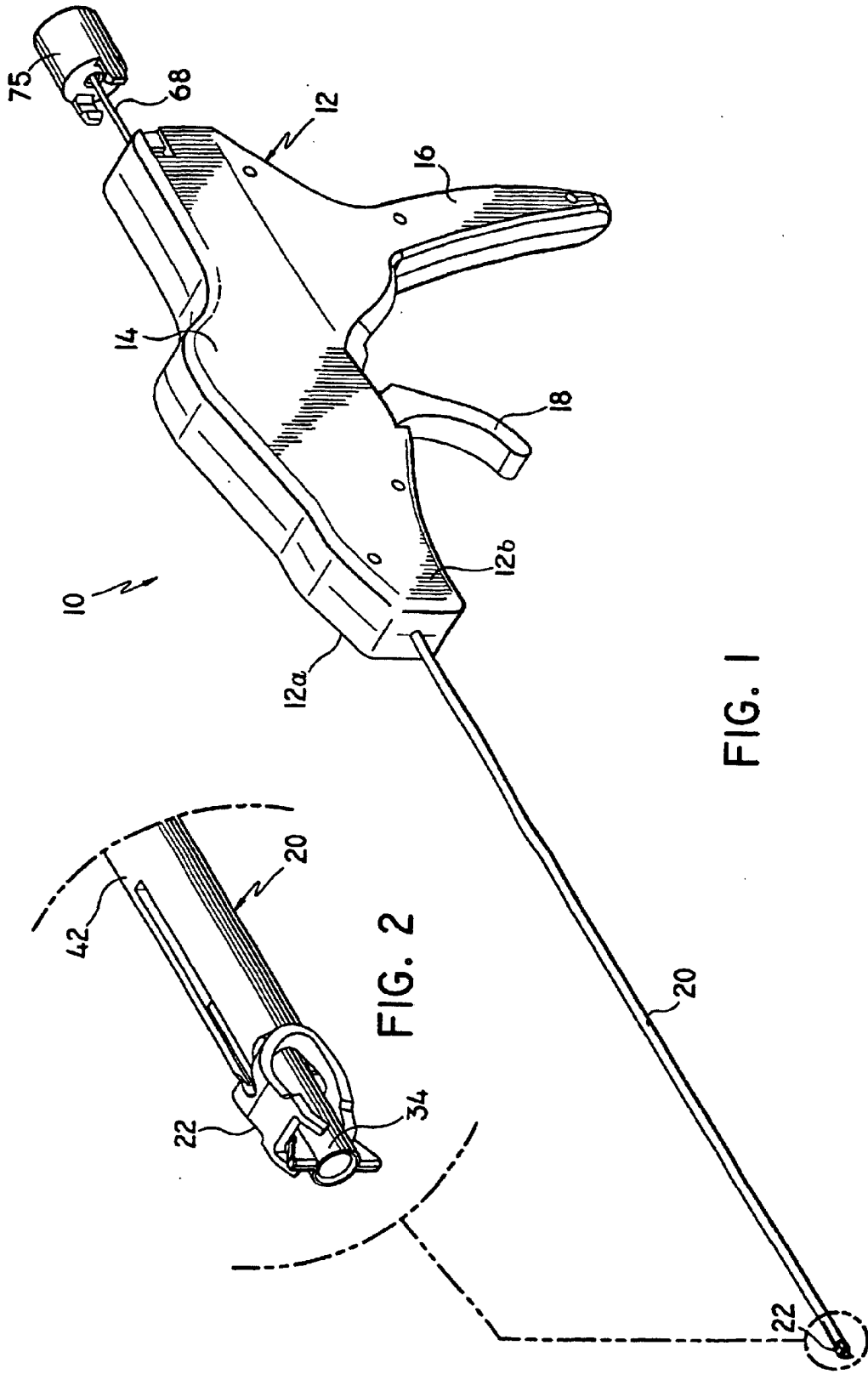
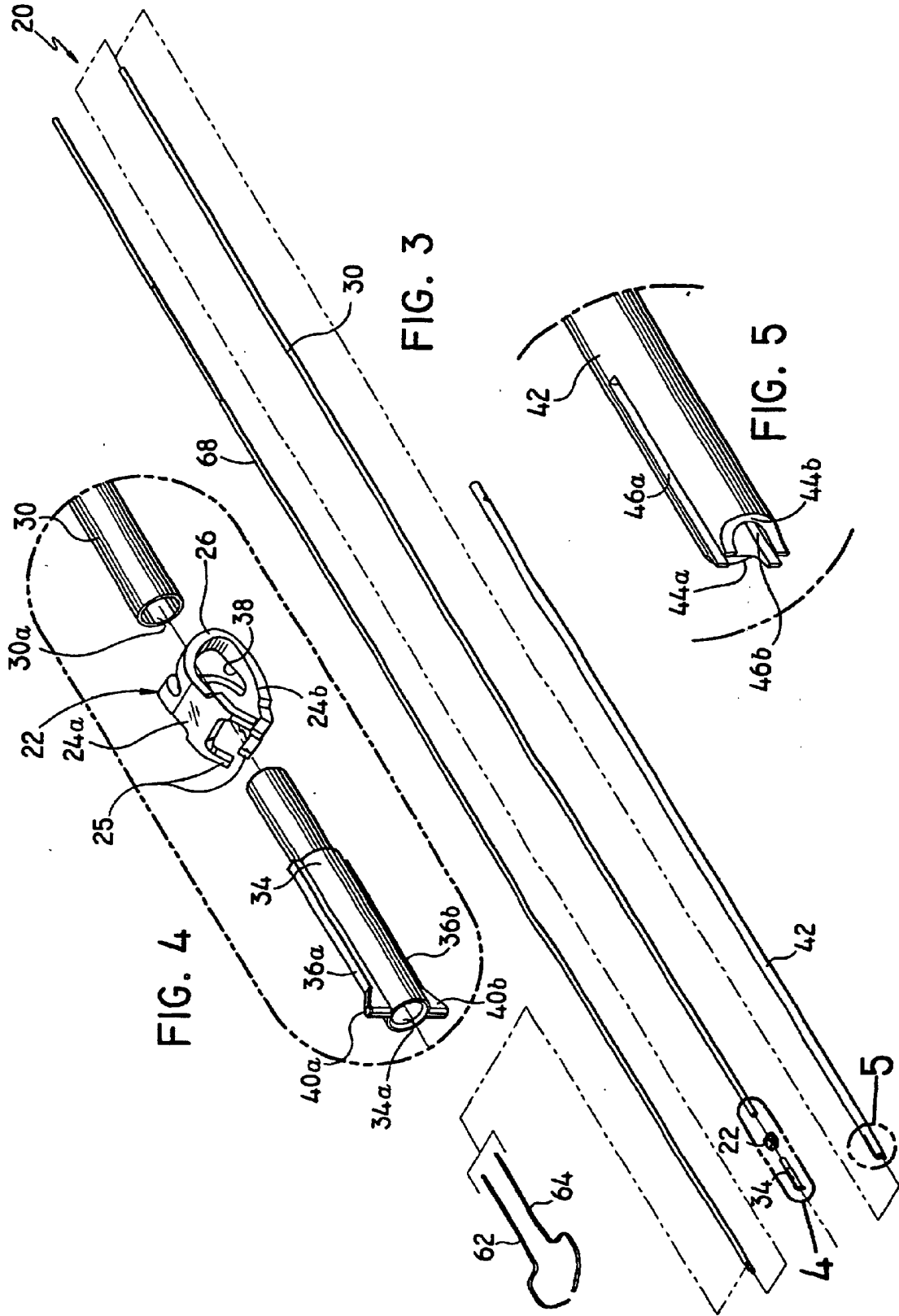

FIG. 1

FIG. 2



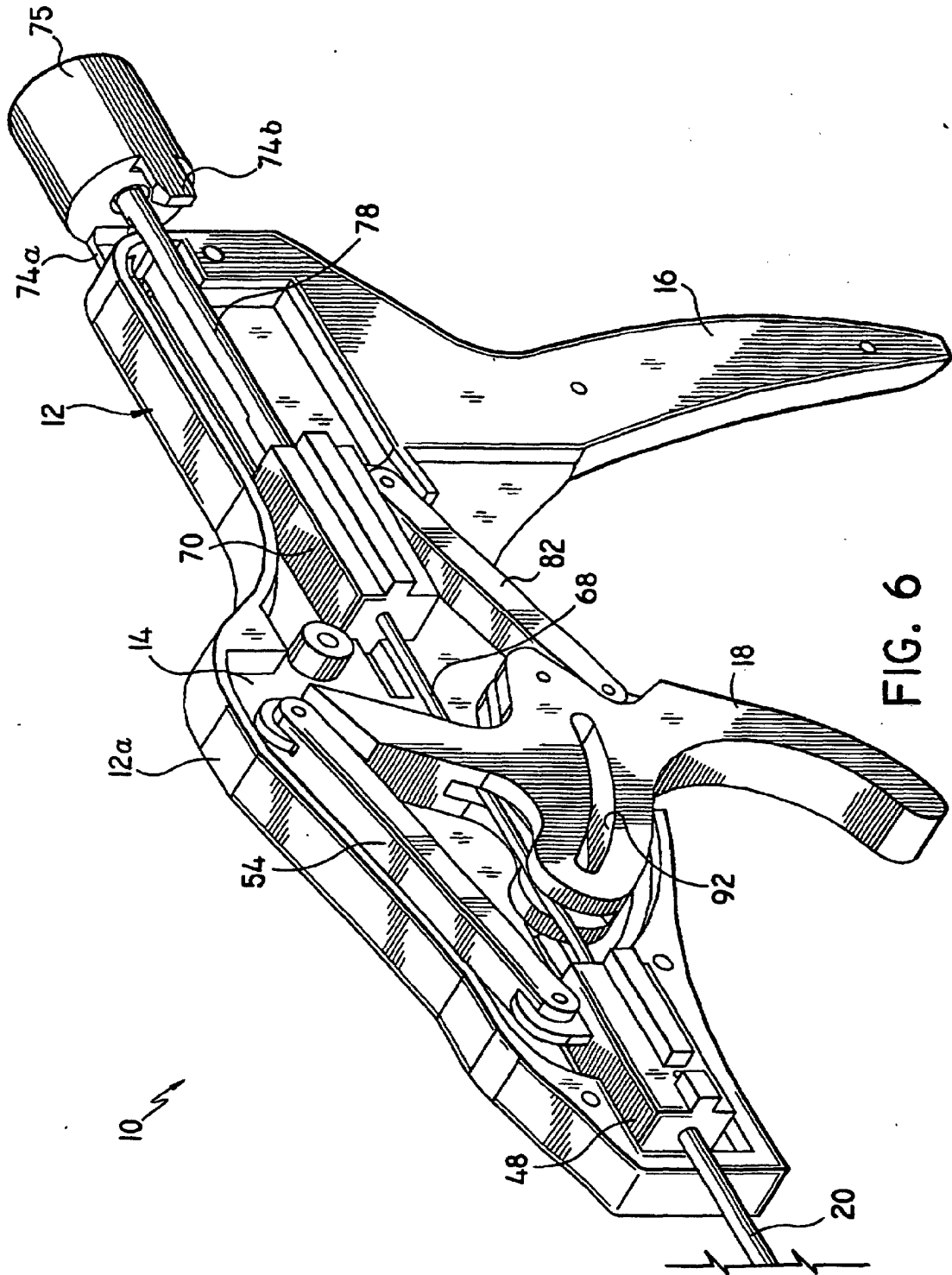

FIG. 6

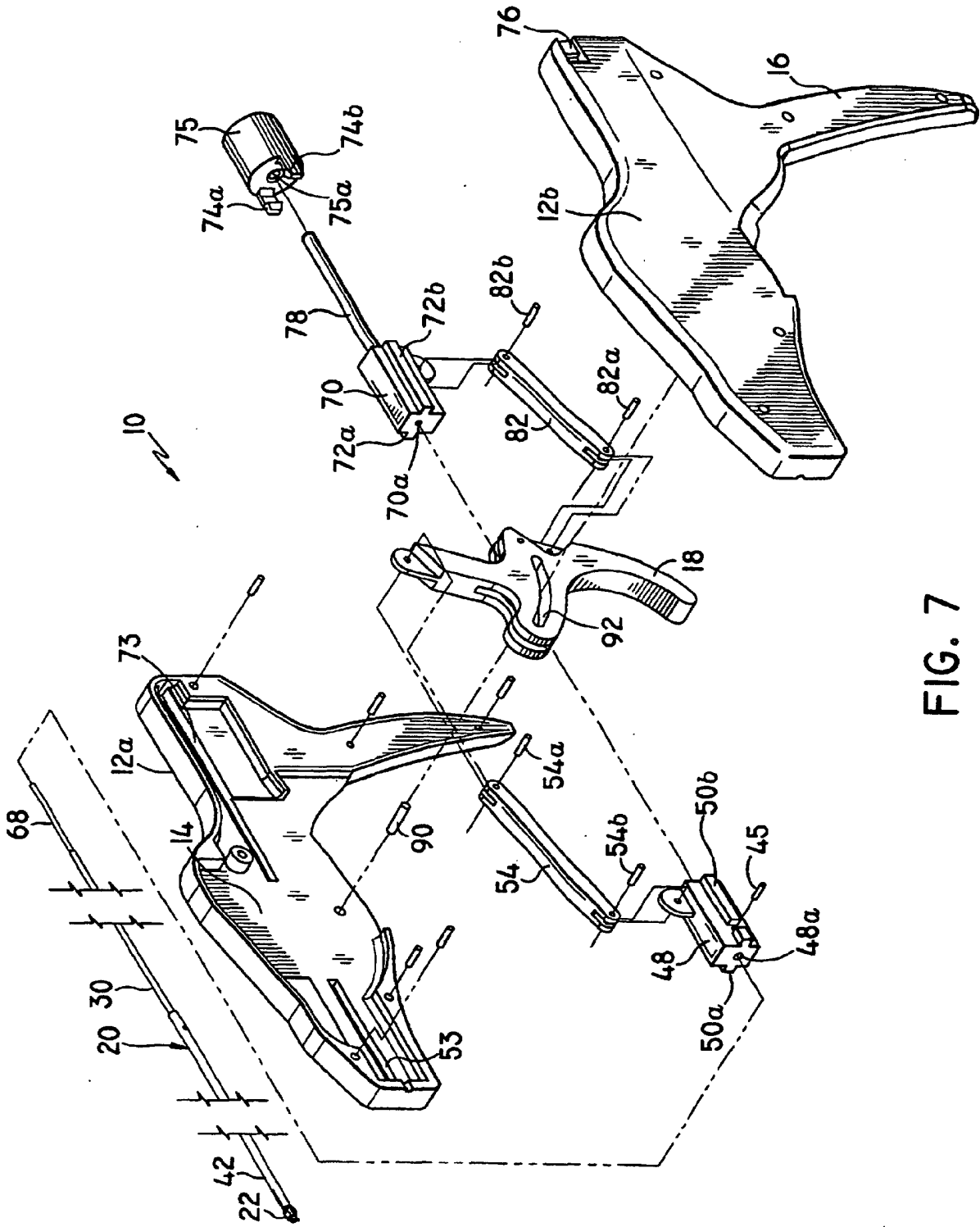
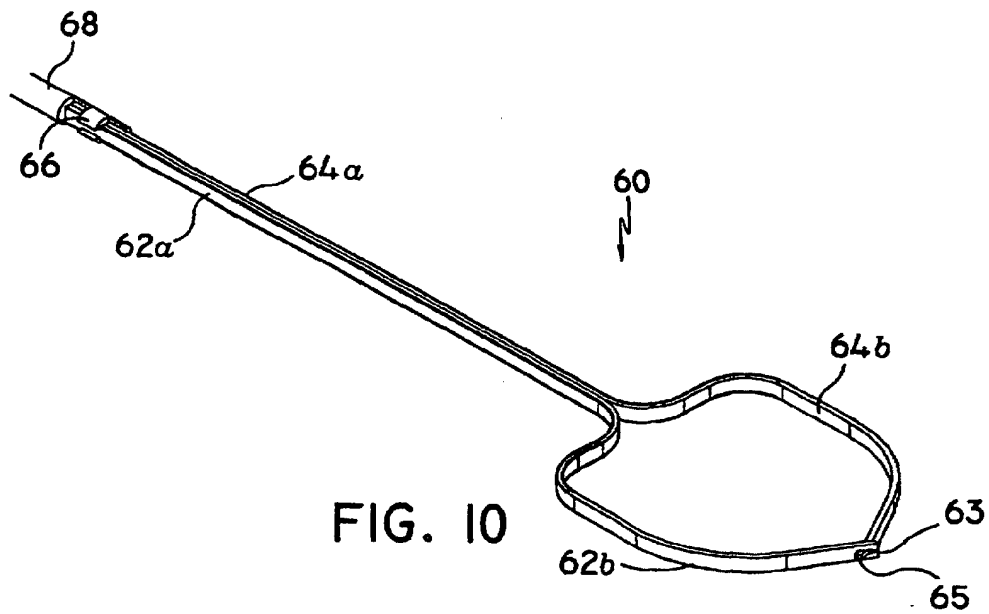
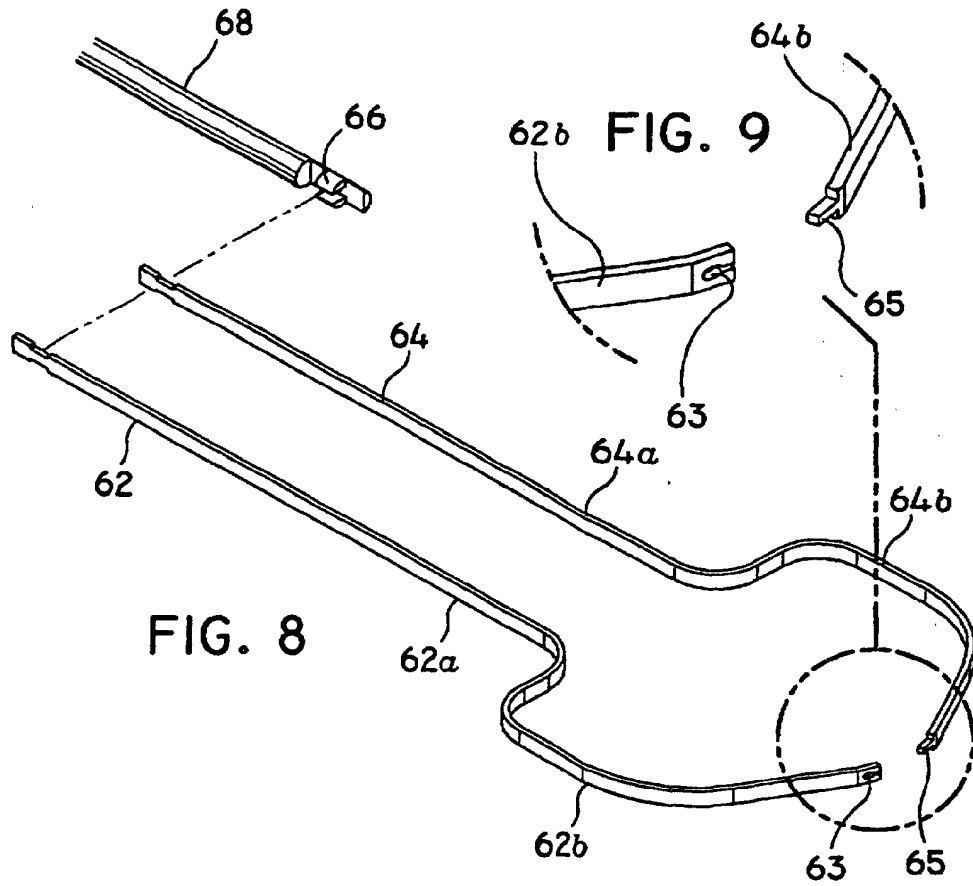

FIG. 7



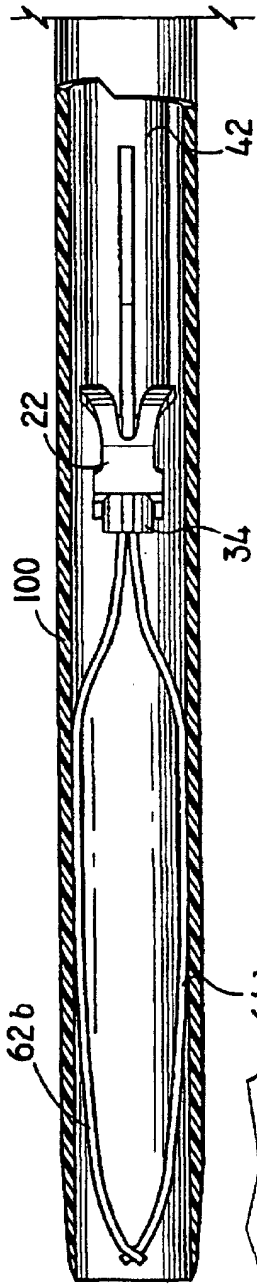

FIG. 12

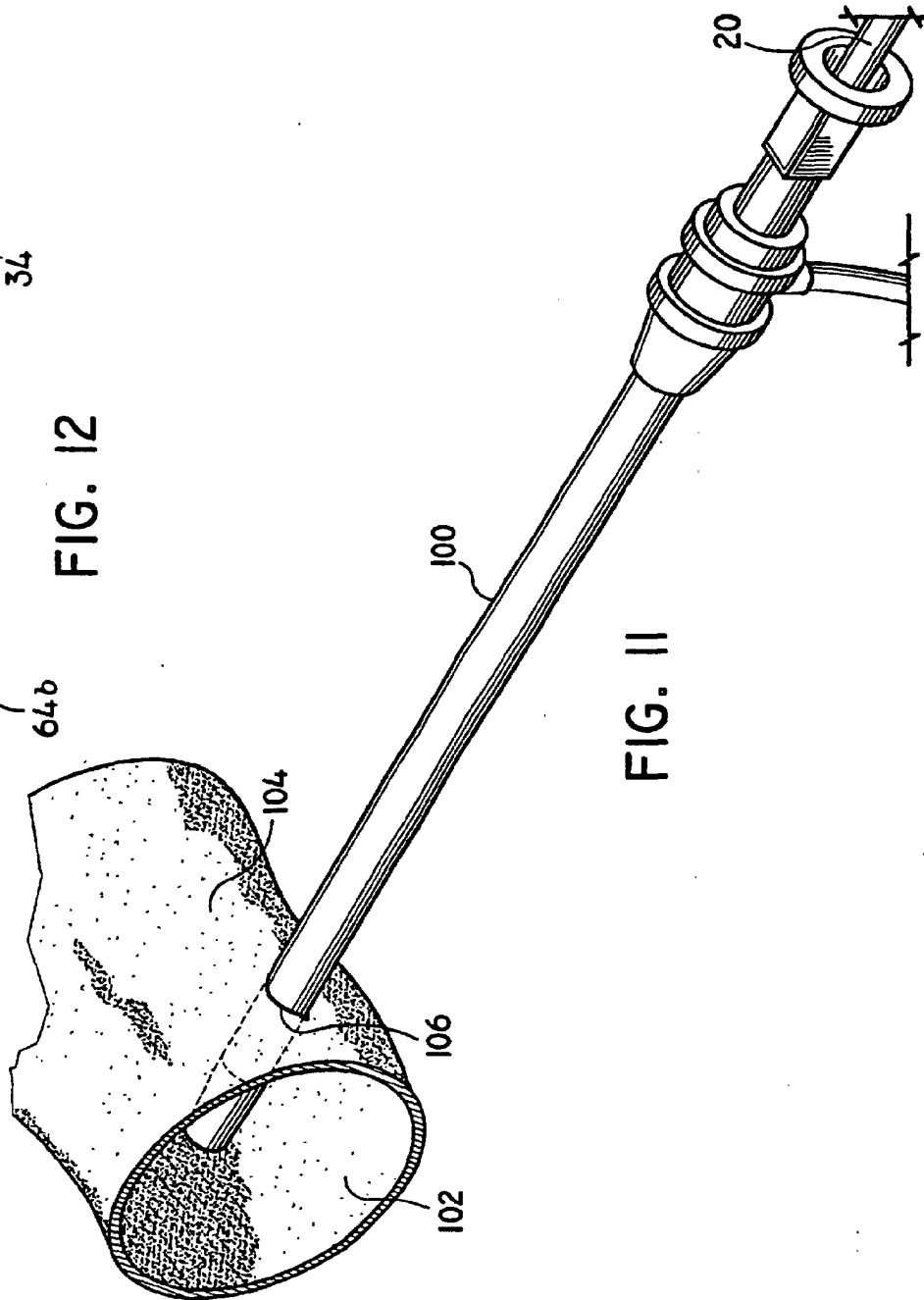
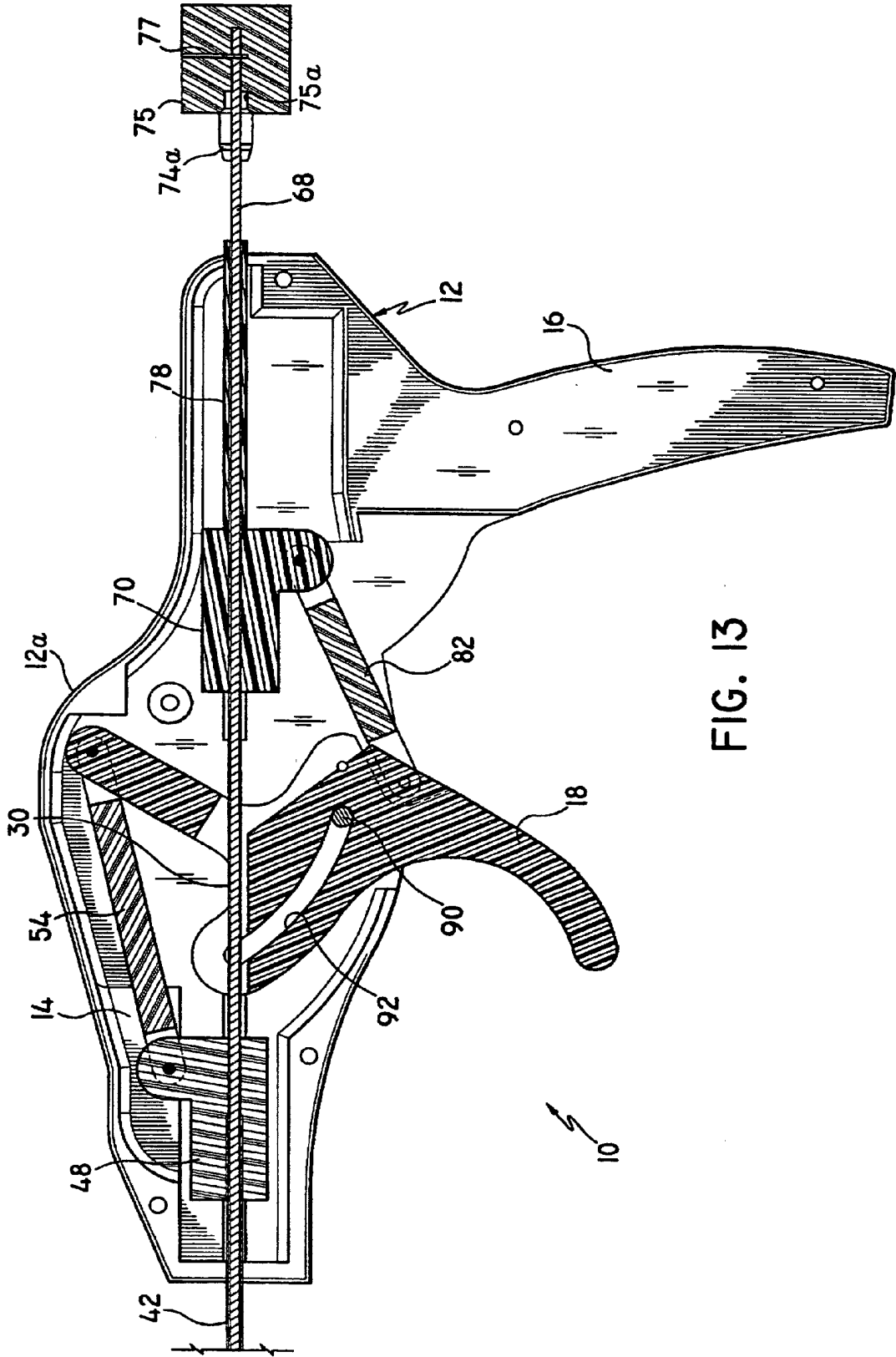
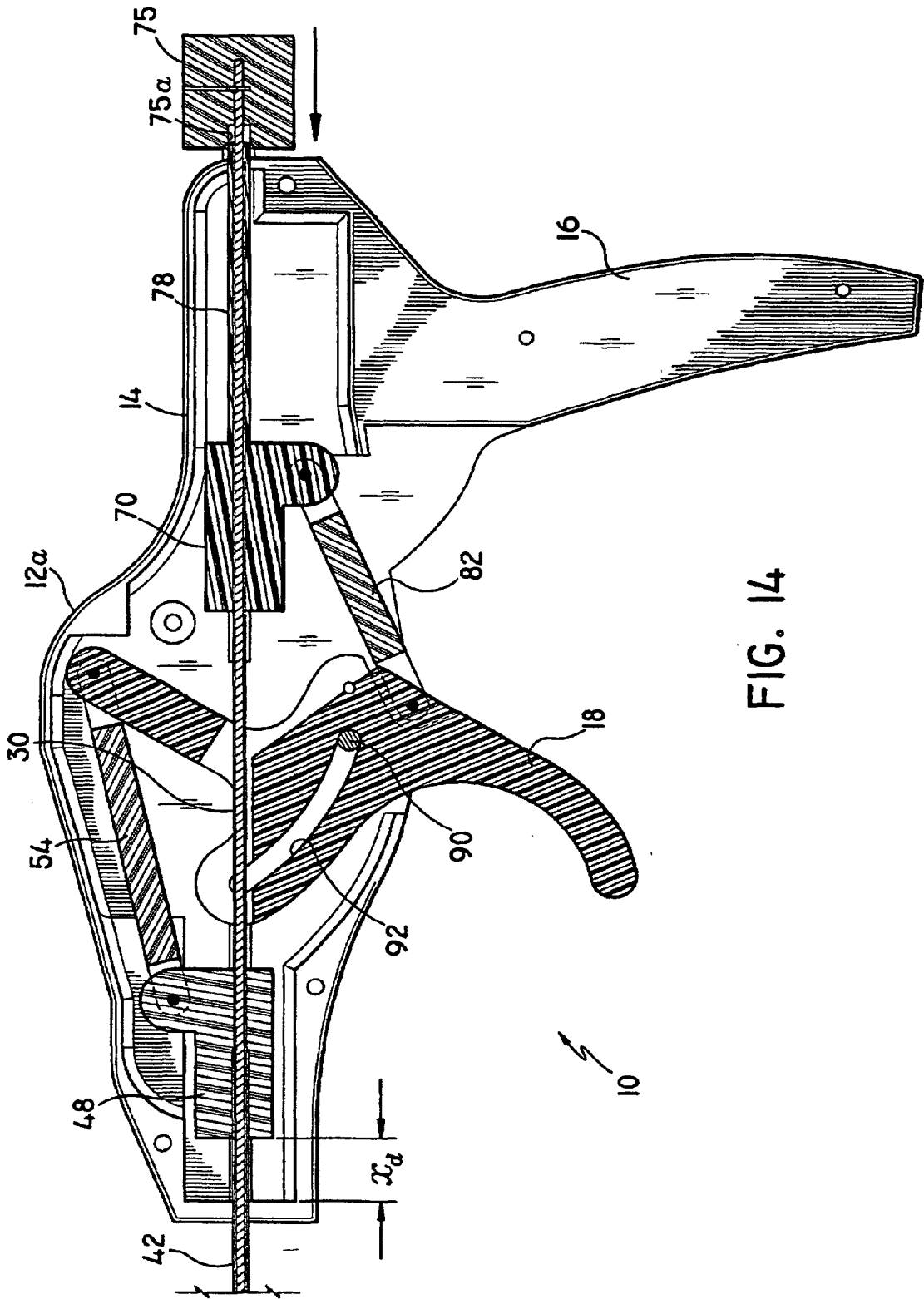
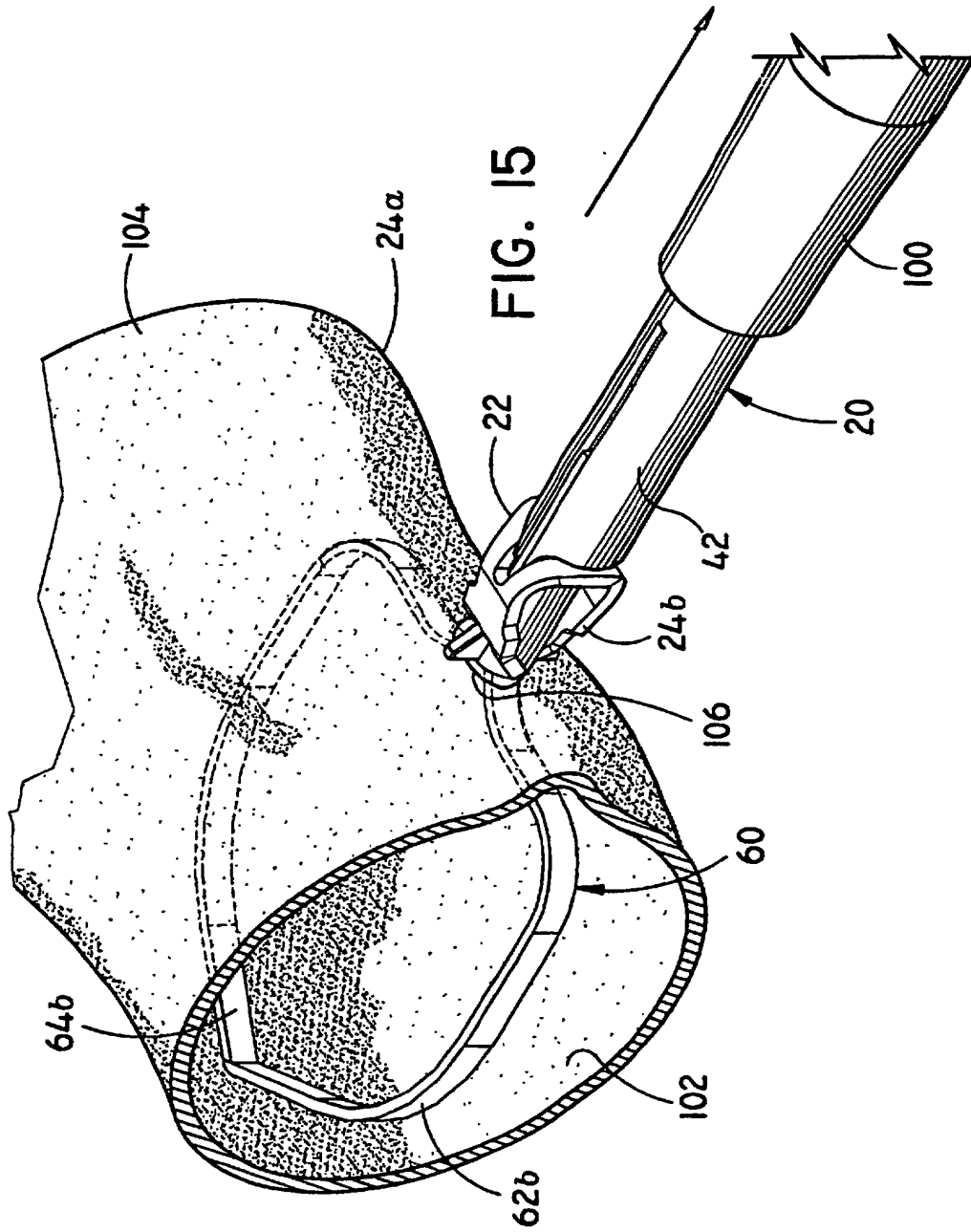
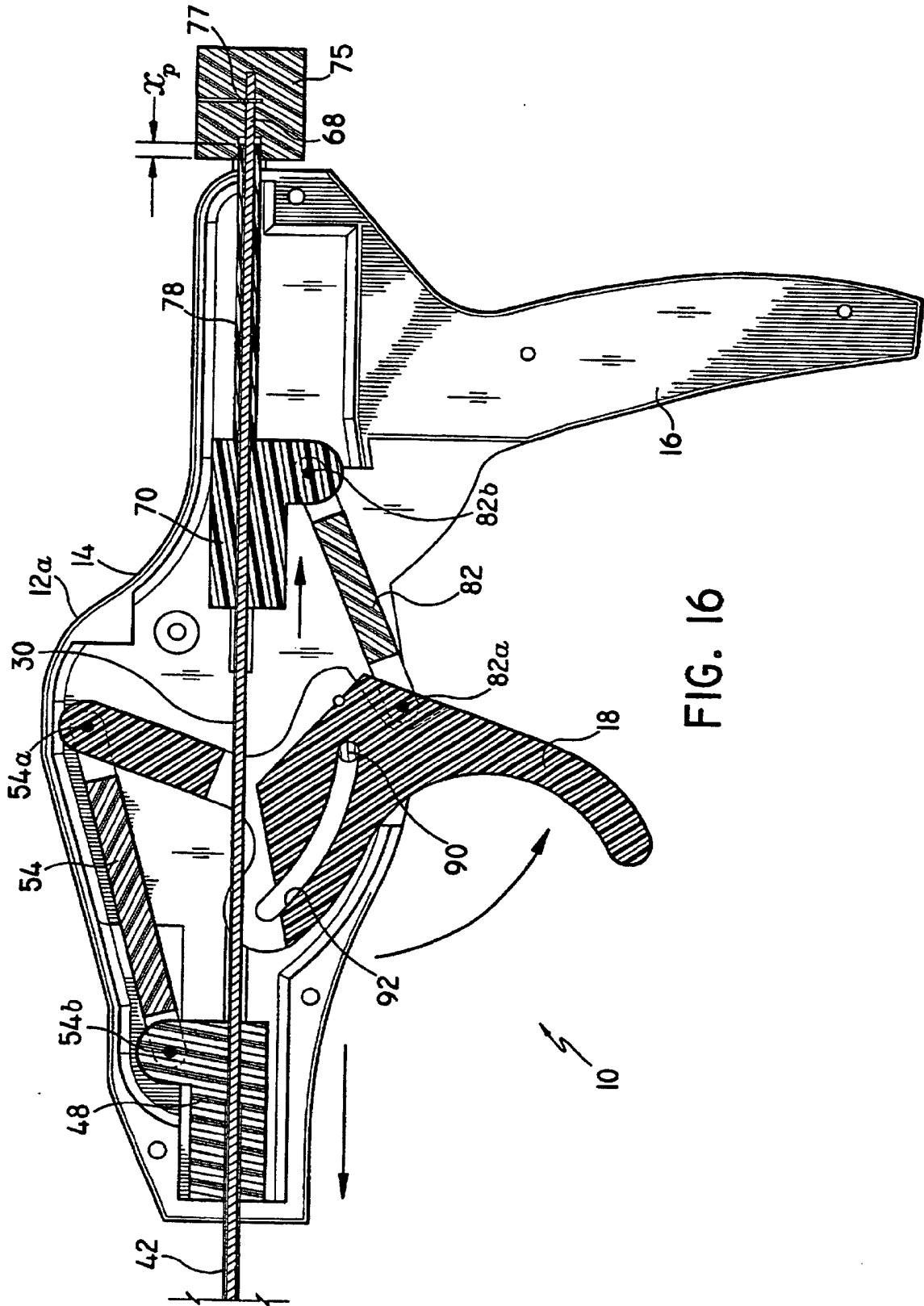

FIG. 11









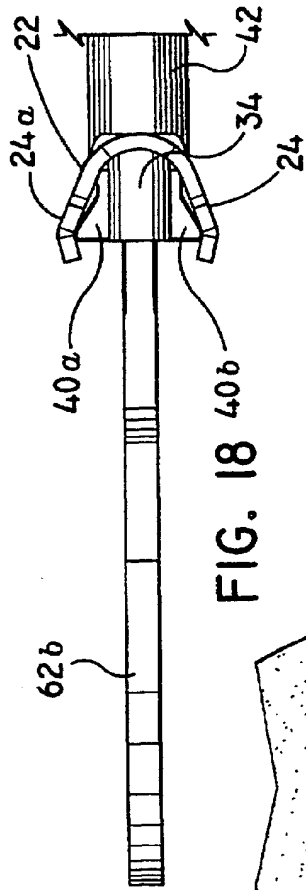

FIG. 18

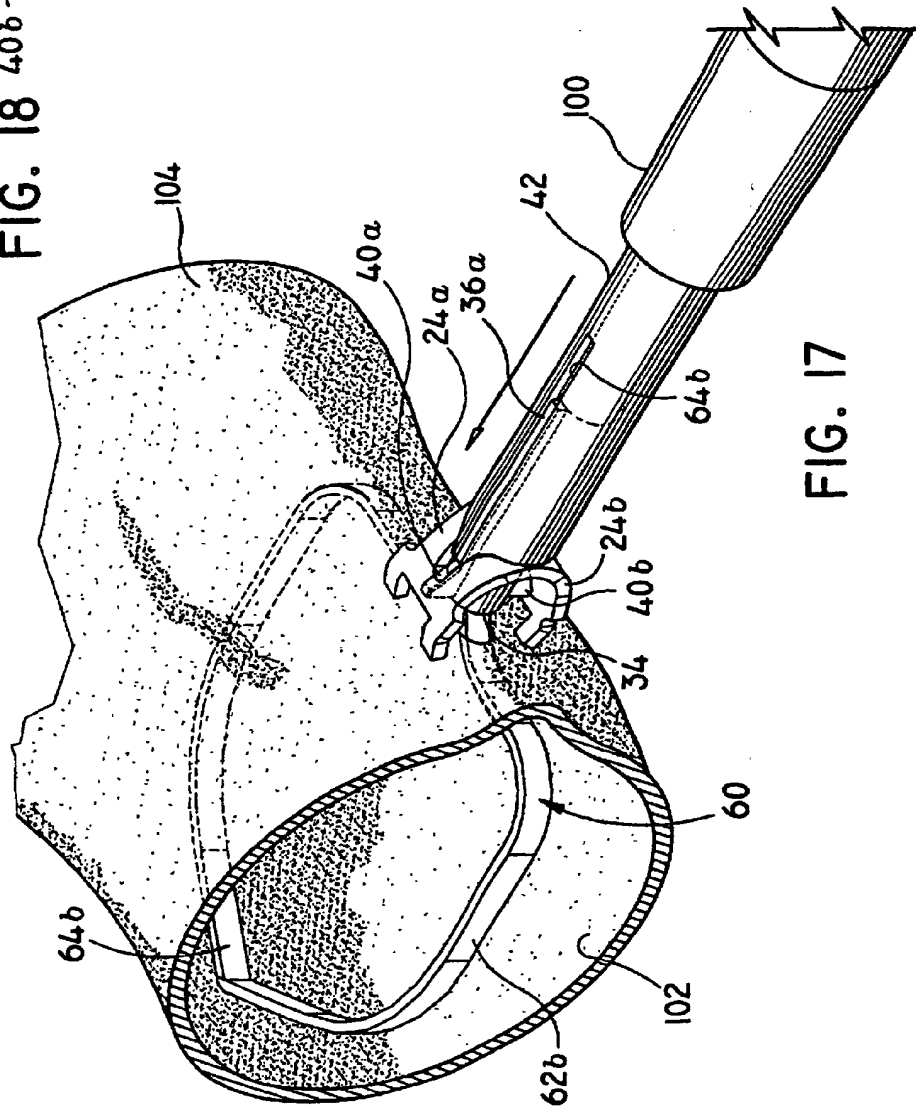

FIG. 17

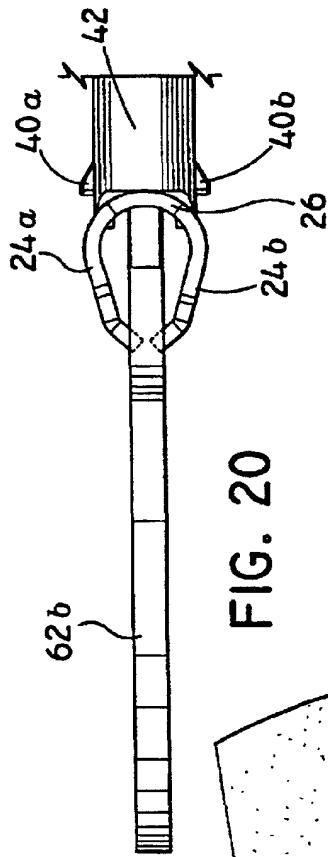

FIG. 20

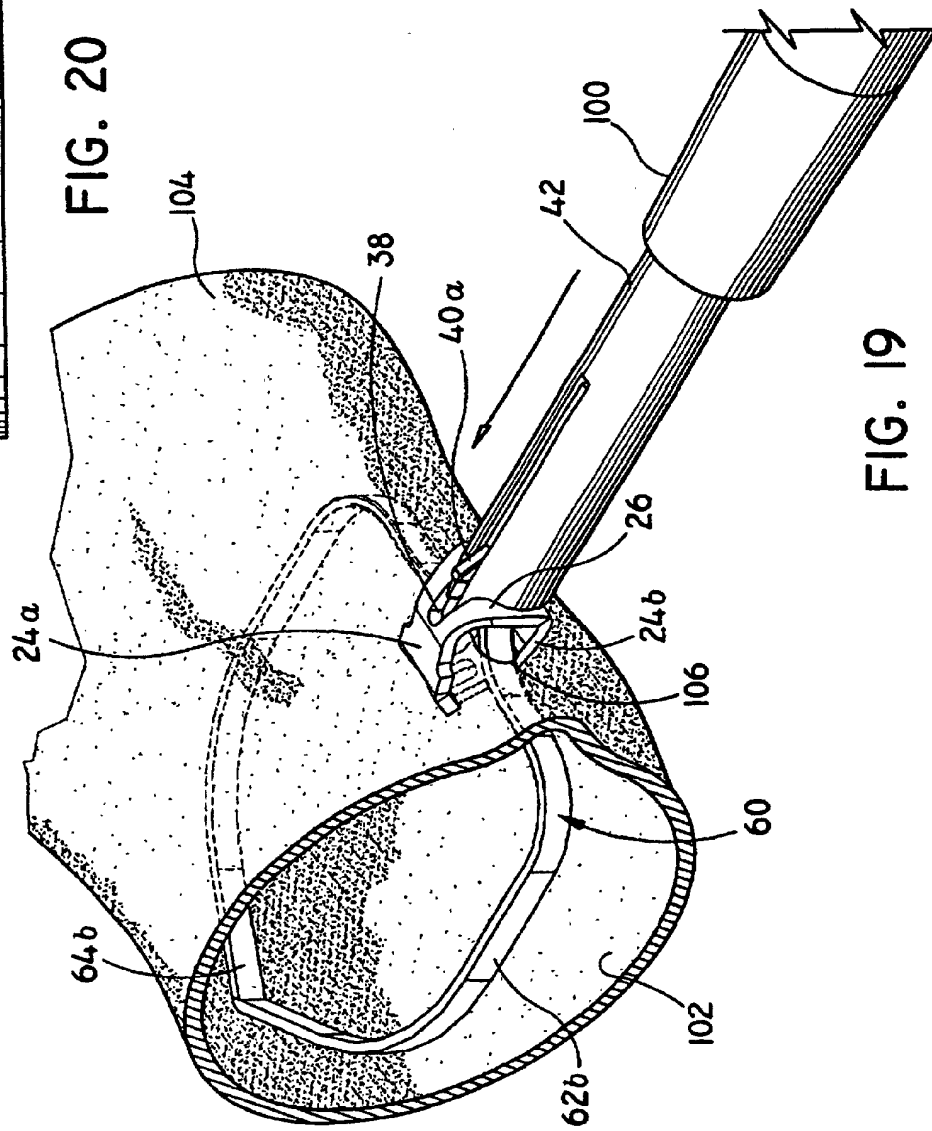

FIG. 19

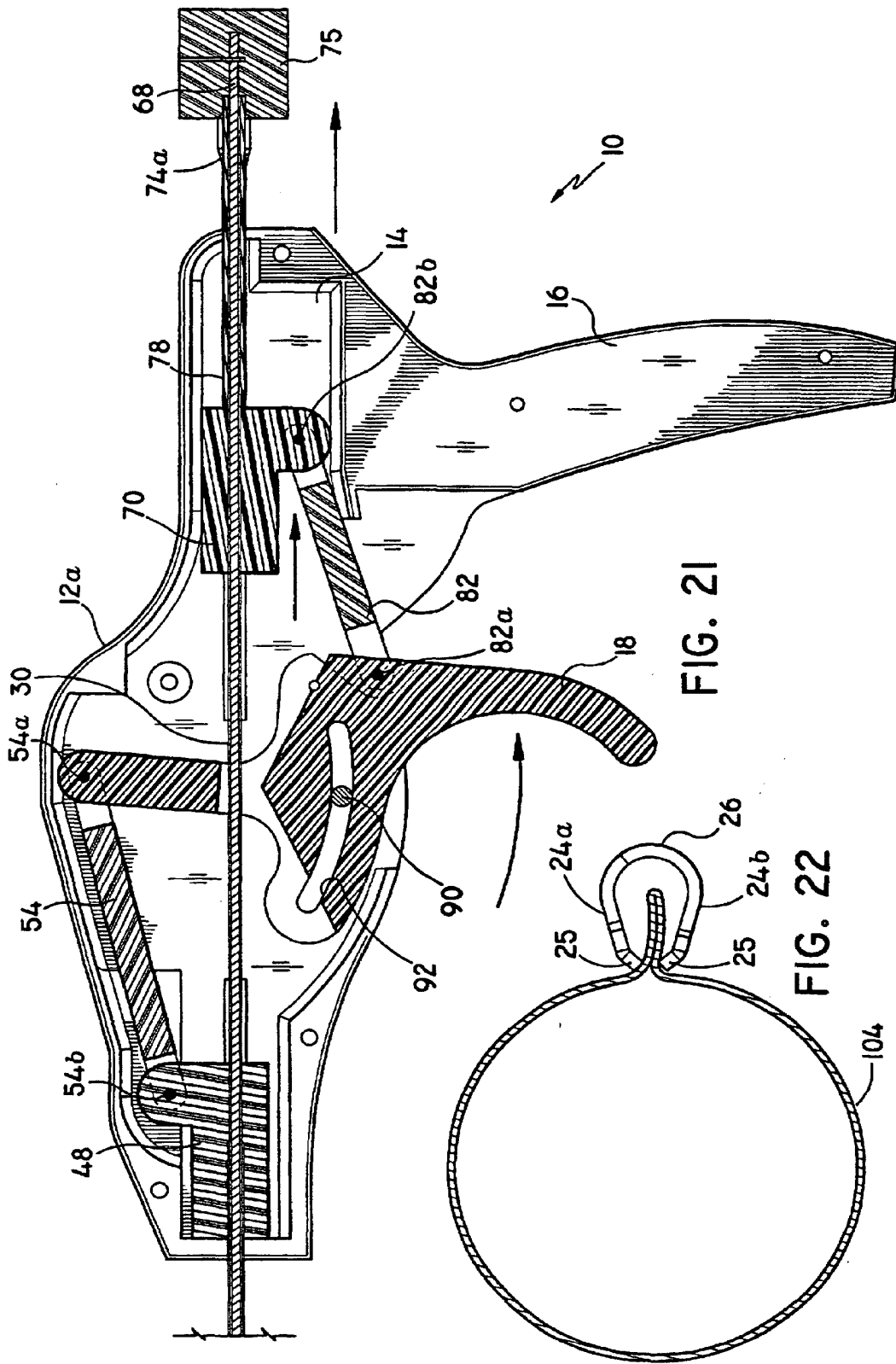

FIG. 21

FIG. 22